



**MECAER | AVIATION | GROUP**

INTEGRATED AIRCRAFT SOLUTIONS

---

**GROUP HIGHLIGHTS**

Mecaer Aviation Group is a leading international provider of solutions for flight control systems, landing systems, cabin comfort systems and distinctive style design, in the helicopter, business and general aviation markets.

MAG has a global presence in the aviation market, reaching over 150MIn USD in revenues and about 500 employees, with seven operating units in Italy, Canada and the USA. Approximately 20% of our employees are focused on state-of-the-art technologies, innovative style and the development of our products.

**TECHNOLOGY**

MAG provides integrated systems and equipment solutions to OEMs, as well as aircraft services to Operators and End-Users, offering the entire activity cycle: design & development, certification, production, including full after-sale support. The MAG concurrent engineering approach, involving both customers and suppliers, goes hand-in-hand with project life-cycle management, and utilizes its diverse technologies in mechanics, hydraulics, electromechanics, electronics and composites.

MAG maintains and expands its engineering knowledge base, manufacturing capabilities and proprietary products through R&D programs. Access to a number of university research departments and a network of engineering subcontractors extends MAG's competences for continuous innovation.

**STYLE**

MAG interiors are a fusion of advanced technology and the Italian passion for style. The collaboration between MAG Design Studio and leading stylists, designers and Italian craftsmen enables the company to offer a wide range of off-the-shelf, tailored or custom-designed solutions for VVIP, VIP, Corporate, EMS and other applications.

**QUALITY**

MAG holds European Aviation Safety Agency (EASA) certifications as Part 21 Design Organization Approval (DOA) and Production Organization Approval (POA), and Transport Canada Civil Aviation (TCCA) POA. In addition it holds MRO airworthiness certifications by EASA, TCCA, Federal Aviation Administration (FAA) and the Italian Civil Aviation Agency (ENAC). MAG is approved and qualified by regulatory agencies, military organizations, industry and customers. MAG is Type Certificate holder for the NH 500D and AMD 500N helicopters.

## LANDING GEAR SYSTEMS

Mecaer Aviation Group offers OEMs Landing Gear Solutions that are safe, reliable and optimized for aircraft performance.



Skid Landing Gear



Wheel brake parking and emergency unit



Control Valves



Control Panels



Nose Landing Gear Struts, Hydraulic Steering



Wheels & Brakes



Main Landing Gear Struts



Hydraulic and Electromechanical Retract Actuators



## ACTUATION AND FLIGHT CONTROL SYSTEMS

Mecaer Aviation Group offers OEMs complete solutions for Precision Control and Maneuverability in Flight.

Flight Control System Simulation

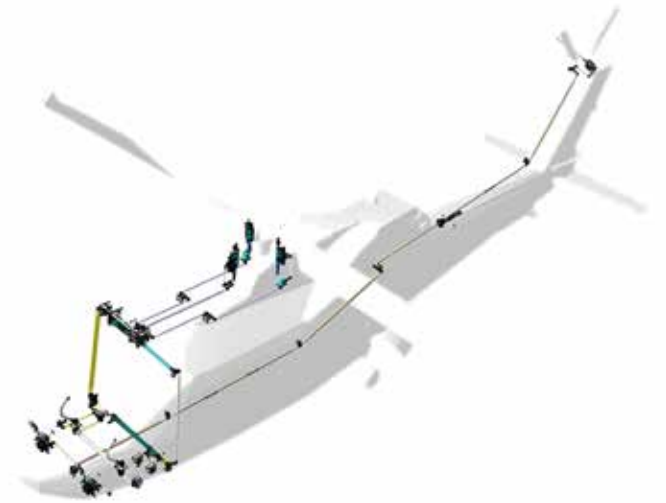
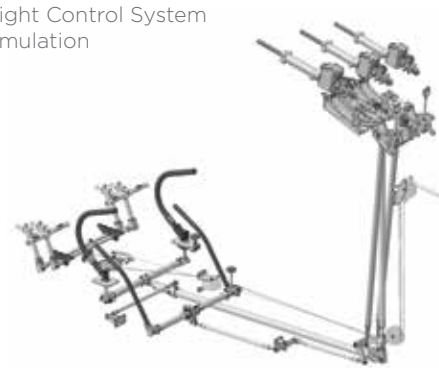

Pedal Assemblies - Command Input -



Composite Control Rods - Command Transmission -



Hydraulic Servo-actuators Rotor Actuation



Pilot Sticks - Command Input -



Mixing Units Cyclic & Collective Mixed Input



Mechanical Flight Controls - Command Transmission -



## CABIN COMFORT SYSTEMS

Mecaer Aviation Group offers to OEMs complete solutions for different mission configurations that integrate Cabin Comfort with Customized Style.



Water Waste Systems

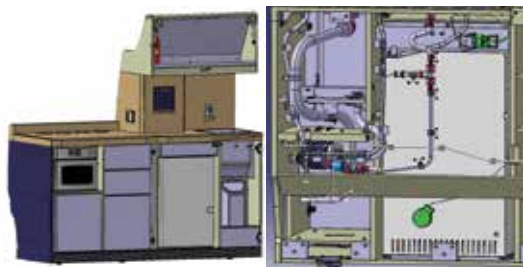

Lighting Systems



Noise & Vibration Abatement Systems

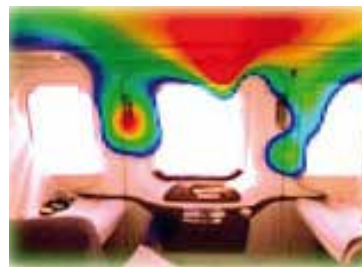

In-Flight Entertainment & Connectivity



Cabin management Systems  
I-Feel Proprietary System



Silens Proprietary System  
Composite Technology



Cabin Air Optimization System



## MAG DESIGN STUDIO

Mecaer Aviation Group in-house design studio combines aeronautical technology with Italian style, to develop highly customized interior designs from concept to aircraft delivery at our Air Center.



## MRO



## LINES OF BUSINESS

---

### ACTUATION & FLIGHT CONTROL SYSTEMS

Hydraulic & Electro-mechanical Actuators - Servo Actuators - Hydraulic Systems - Entire Flight Control Chain - Swaged Control Rods - Control Sticks - Pedal Assemblies - Other components related to the Kinematic Chain - Product Support - Components MRO.

### LANDING SYSTEMS

Landing systems for helicopters and business aircraft - Hydraulic & Electro-mechanical Retraction Systems - Steering Systems - Braking Systems - Control Panels - Control Valves - Hydraulic Reservoirs - Wheels and Brakes - Product Support - Components MRO.

### CABIN COMFORT SYSTEMS

Design, development and production of Interior Systems for OEMs - Technological proprietary products such as Noise & Vibration Abatement System, Cabin Management Systems, IFE Systems, Cabin Air Optimization Systems, Lighting and Electrical Systems, Water Waste Systems, Cabinet & Monuments.

### AIRCRAFT SERVICES

#### *MRO*

Complete Maintenance, Repair and Overhaul of helicopters - Interiors Kit installation,zzRefurbishment, Modification and Green Completion of fixed and rotary wing aircraft - Equipment and components Overhaul.

#### *MAG DESIGN STUDIO*

MAG's style center offers style solutions tailored to Customers' needs - MAG Design Studio is committed to establish its own brand and the Italian Style in the international markets.

## MAG Operating Units

---

### **Borgomanero - Italy (HQ)**

Via per Arona 46  
28021 Borgomanero  
Novara  
Italy  
Tel. +39.0322.837.1

### **Monteprandone - Italy**

Via dell'Artigianato 1  
63076 Monteprandone  
Ascoli Piceno  
Italy  
Tel. +39.0735.709.1

### **Roma - Italy**

Via Giambattista Vico 1  
00196  
Roma  
Italy  
Tel. +39.06.454.284.25

### **Laval (Montreal) - Canada**

Mecaer America Inc.  
5555 William-Price  
Laval QC H7L6C4  
Canada  
Tel. +1.450.682.7117

### **Philadelphia - USA**

MAG Inc.  
9800 Ashton Road  
Box 1, Philadelphia  
PA 19114 USA  
Tel. +1.267.341.0130

### **Irving (Dallas) - USA**

MAG Inc.  
300 E. John Carpenter  
Freeway Suite 1075  
Irving TX 75062 USA  
Tel. +1.972.717.2900